

**isc Silicon PNP Power Transistor**

**2SA1930**

**DESCRIPTION**

- High Transition Frequency :  $f_T=200\text{MHz(Typ.)}$
- Complementary to 2SC5171

**APPLICATIONS**

- Power amplifier applications
- Driver stage amplifier applications

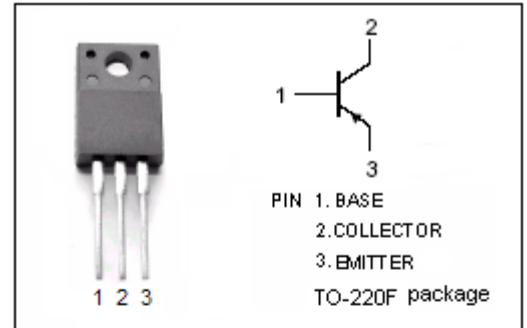

**ABSOLUTE MAXIMUM RATINGS( $T_a=25^\circ\text{C}$ )**

SYMBOL	PARAMETER	VALUE	UNIT
$V_{CBO}$	Collector-Base Voltage	-180	V
$V_{CEO}$	Collector-Emitter Voltage	-180	V
$V_{EBO}$	Emitter-Base Voltage	-5	V
$I_C$	Collector Current-Continuous	-2	A
$I_B$	Base Current-Continuous	-1	A
$P_c$	Collector Power Dissipation @ $T_C=25^\circ\text{C}$	20	W
$T_J$	Junction Temperature	150	$^\circ\text{C}$
$T_{stg}$	Storage Temperature Range	-55~150	$^\circ\text{C}$

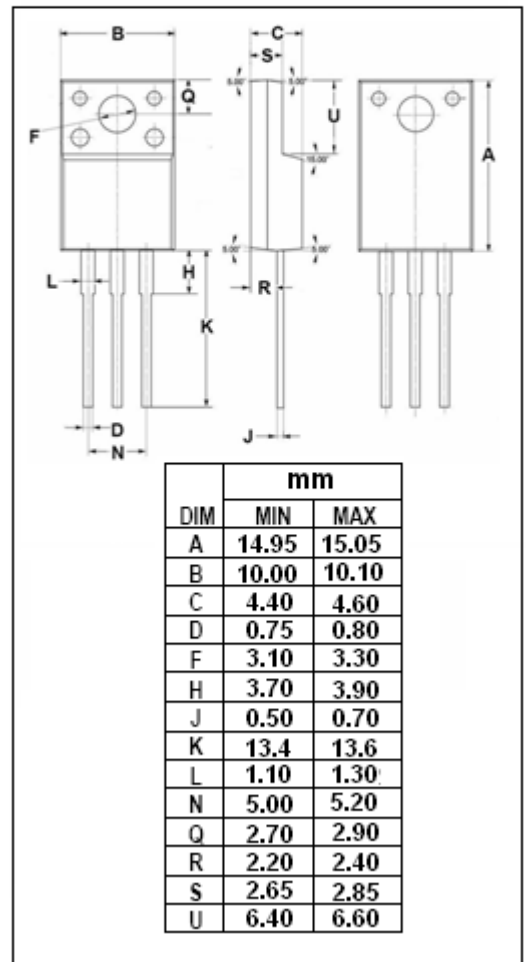

**isc Silicon PNP Power Transistor****2SA1930****ELECTRICAL CHARACTERISTICS** $T_C=25^{\circ}\text{C}$  unless otherwise specified

SYMBOL	PARAMETER	CONDITIONS	MIN	TYP.	MAX	UNIT
$V_{CEO(SUS)}$	Collector-Emitter Sustaining Voltage	$I_C = -10\text{mA}; I_B = 0$	-180			V
$V_{CE(sat)}$	Collector-Emitter Saturation Voltage	$I_C = -1.0\text{A}; I_B = -0.1\text{A}$			-1.0	V
$V_{BE(on)}$	Base-Emitter Voltage	$I_C = -1\text{A}; V_{CE} = -5\text{V}$			-1.5	V
$I_{CBO}$	Collector Cutoff Current	$V_{CB} = -180\text{V}; I_E = 0$			-5	$\mu\text{A}$
$I_{EBO}$	Emitter Cutoff Current	$V_{EB} = -5\text{V}; I_C = 0$			-5	$\mu\text{A}$
$h_{FE-1}$	DC Current Gain	$I_C = -0.1\text{A}; V_{CE} = -5\text{V}$	100		320	
$h_{FE-2}$	DC Current Gain	$I_C = -1\text{A}; V_{CE} = -5\text{V}$	50			
Cob	Collector Output Capacitance	$I_E = 0; V_{CB} = -10\text{V}, f=1\text{MHz}$		16		pF
$f_T$	Current-Gain—Bandwidth Product	$I_C = -0.3\text{A}; V_{CE} = -5\text{V}$		200		MHz